

# elmob

## Lynx LY1931/BK

Elmob By Optimum

Lynx LY1931/BK

High Gloss Black

The Lynx Elmob by Optimum cantilever range of LCD and plasma stands incorporates many outstanding features.

It includes a 26 degree left and right swivel bracket, hidden castors for ease of movement, toughened safety glass and integral cable management system.

It includes ten high quality laminates to add a particular finish to the stand to match your individual tastes.

**Elmob - focused on a solution**

**Features:**

- Suitable for up to 42" screens
- High gloss black shelves
- High gloss black aluminium
- 26 degree left and right movement of the screen mount
- Flush mounted castors
- 10 high quality laminates



Model Shown Elmob Pegasus PE2934/BK

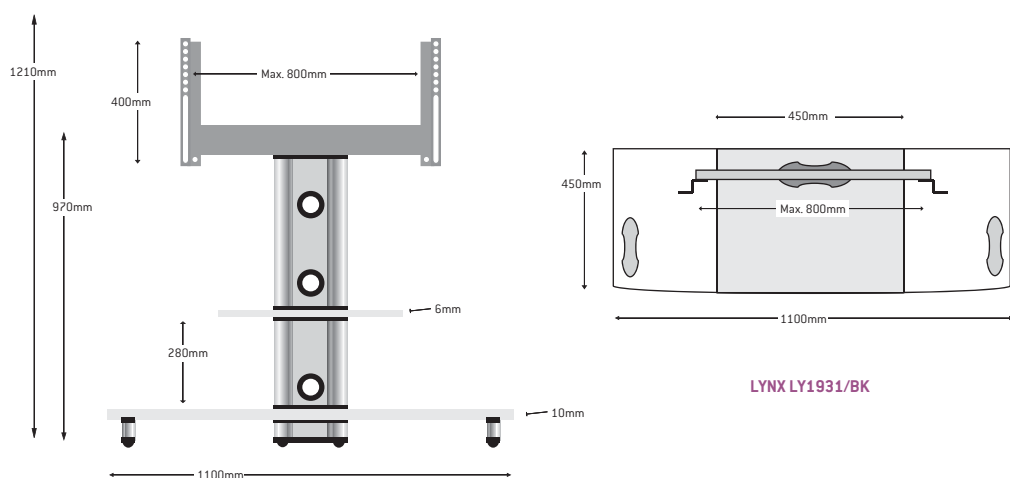

FRONT ELEVATION

PLAN ELEVATION

• Barcode: 8 697452 125065

• Overall Weight: 25kg

• Height: 1210mm

• Depth: 450mm

• Width: 1100mm

• Internal Width: 1100mm

• Weight Load: 60kg

