

ST35 Loudspeaker Stands

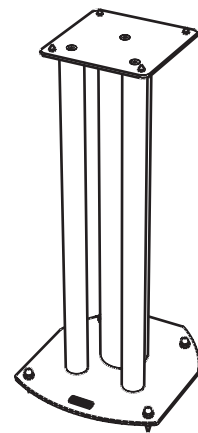

Thank you for purchasing this Epos Acoustics ST35 Speaker Stand. This stand has been designed specifically for use with the ELS 3 and M5 speaker range.

Assembly



Kit list:

- Base Plate x1
- Top Plate x1
- Large Support Tube x1
- Small Support Tube x2
- Adjustable Floor Spike Plus bolt x4
- Dome Nut x4
- Top Spikes (Optional) x4
- M6 Hex Screw x6
- Allen Key x1
- 10/13mm Spanner x1

NOTE:

The height of the ST35 Stand is determined by the position of the Floor Spike Locking Nut. To adjust the height of the ST35 stand, you will need the supplied spanner and a Spirit Level. Simply decide on a suitable position, check with a Spirit Level and lock using the supplied spanner.

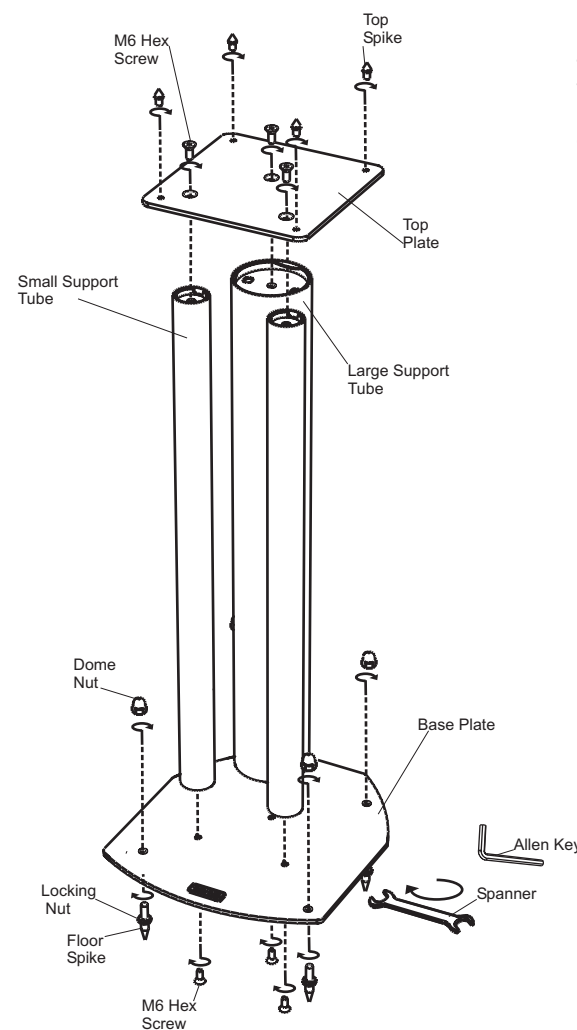

Cable management

The ST35 Cable management allows you to run speaker cable through the main support columns. We recommend running the cables through the main column prior to the connection of your loudspeakers. Making use of the Cable management system will allow you to run the cables at ground level, thus keeping cables tidy and in place.



Positioning

As every room is different, we strongly recommend that you experiment with the positioning of your loudspeakers. Place the speaker so the tweeter is at eye level (when sitting). Remember, the closer the speaker is to sidewalls or corners, the more bass is reflected back at the listener. If you find you are creating a 'BOOM' effect with positioning, try moving them out into the room to correct the balance of sound.

Finally, be sure you are happy with how your system sounds, if it sounds correct, then go with it!

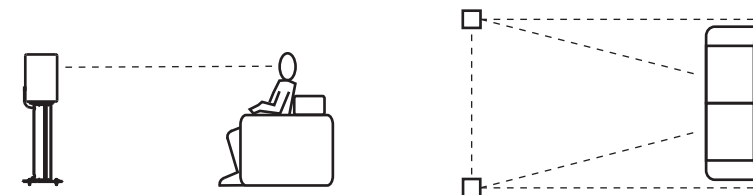

www.epos-acoustics.com

EPOS LIMITED, 12 AVEBURY COURT, MARK ROAD, HEMEL HEMPSTEAD, HP2 7TA. ENGLAND Tel: +44(0)1442 260146

Scale NTS (1:1 only)	Colour Definition Pantone	Drawing Title Epos ST35 Speaker Stand Instructions		Revisions & Date 1: 02/07/04 ORIGINAL 2: 20/12/05 UPDATE 3: 4: 5:
Sheet N/A	Material 130gms Paper			
Drawn MW	Checked By	Signed off	Drawing No. ***	